

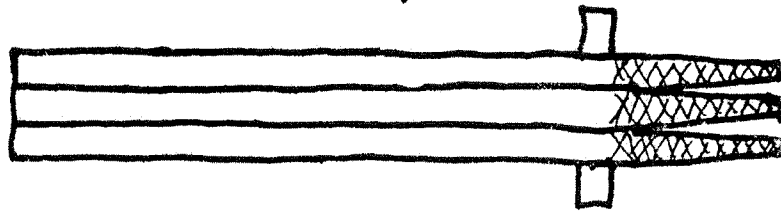

Hoisting the Scuttlebutt A Comprehensive Guide

By Joe Alger

- ①
- ②
- ③
- ④
- ⑤
- ⑥
- ⑦
- ⑧

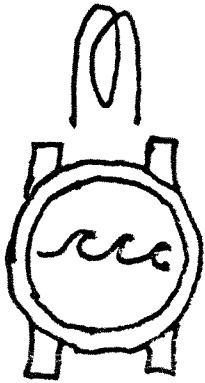

⑨

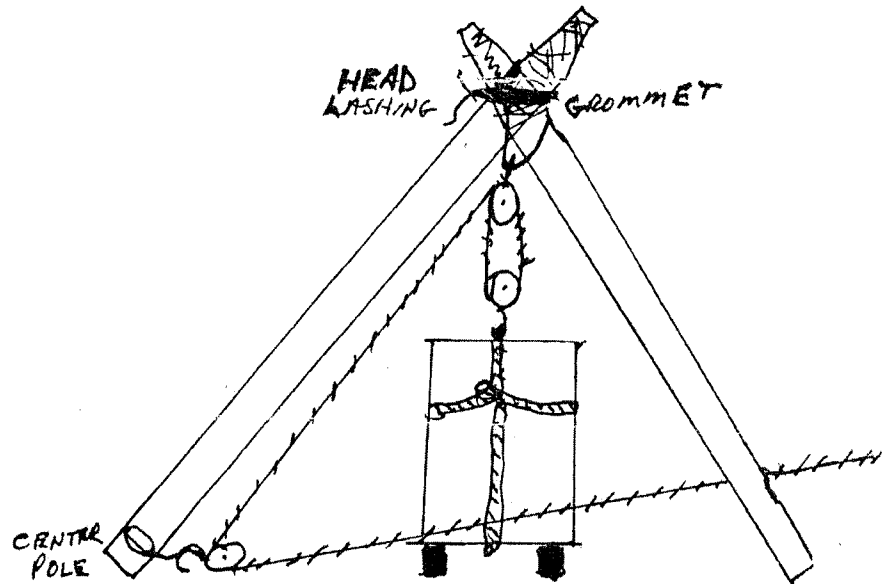
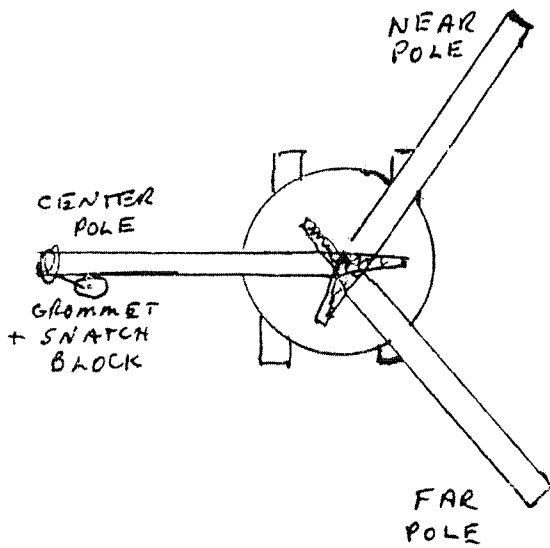

HAULING LINE BETWEEN
NEAR AND FAR POLE
EITHER SIDE OF BARREL

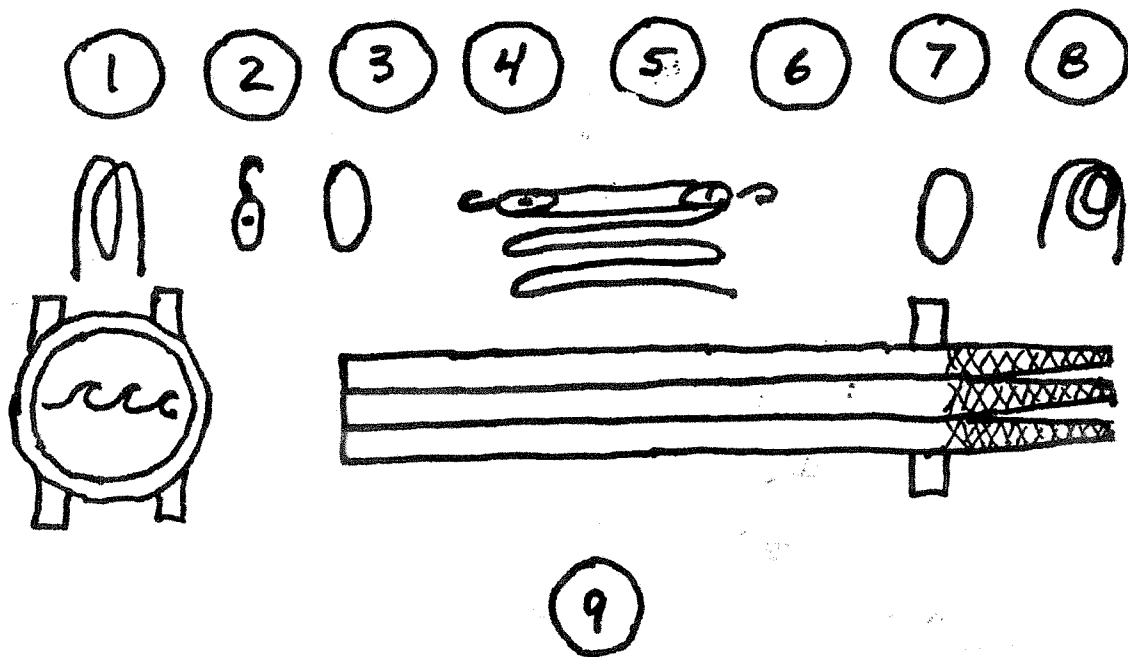

Barrel Hitch #1 – Set up Gear as directed before initial run

Start at attention

Feed line to far side of barrel

Bring loop to top of barrel

Tie square knot

Center Hitch

Guide barrel up and down

Untie knot

Maintain loop. Stay at barrel until center pole clears

Coil line

Return to attention

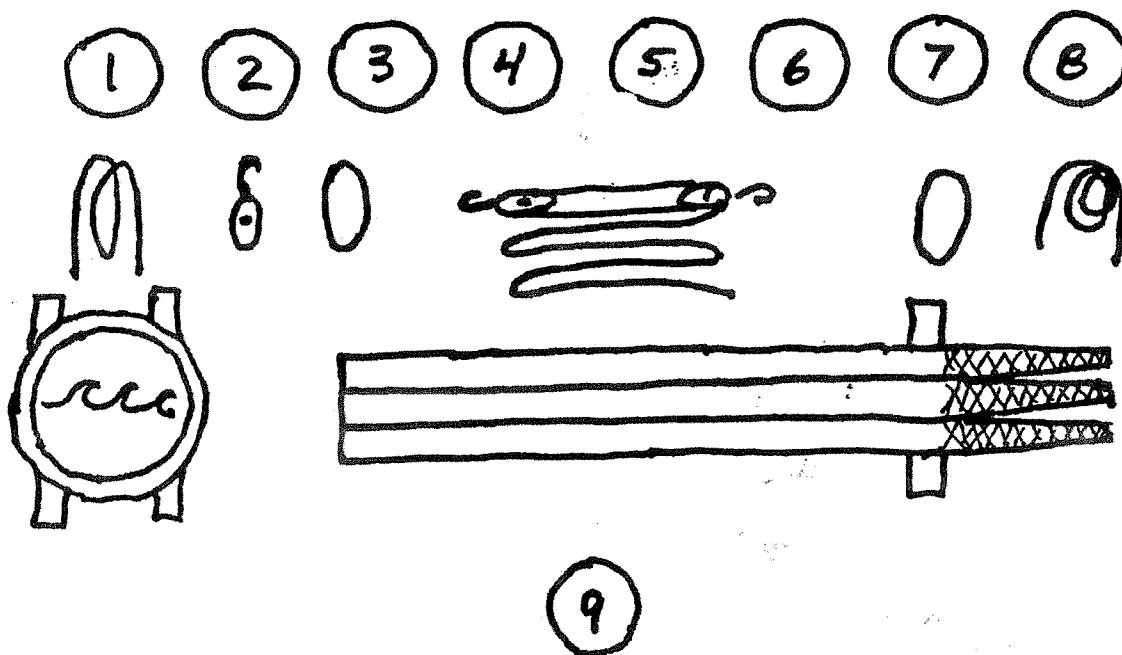

Barrel Hitch #2 – Set up Gear as directed before initial run

Start at attention

Take snatch block behind barrel hitch #1 & drop for center pole

Pull line at far side of barrel – reach under barrel

Tie square knot

Center Hitch

Guide barrel up and down

Untie knot

Let center pole clear

Pick up snatch block and grommet if necessary

Return to attention

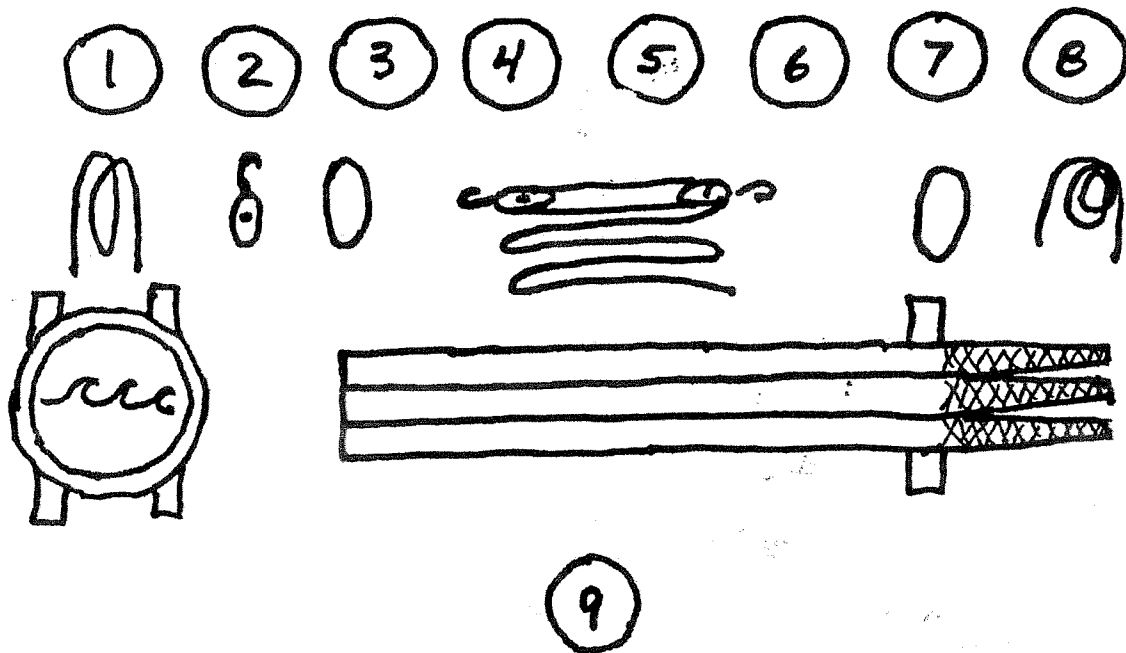

Center Pole #3 – Set up Gear as directed before initial run

Start at attention

With back to barrel, loop grommet at base of center pole

Hold pole so tapers line up – watch popper

Lift and twist pole

Guide pole around barrel (DO NOT PULL!) Set pole approx. 5' past barrel

Hook up snatch block and hold open for line; close and latch snatch block

Wrap legs around pole with feet on grommet

Take up slack on tackle when ready

Keep crew from hauling until ready

Assist barrel up and down

Clear snatch block

Push tripod over – DON'T STOP! Push barrel Hitch #1 & #2 out of way if needed.

Twist and pull out center pole

Put butt to barrel and line up all poles

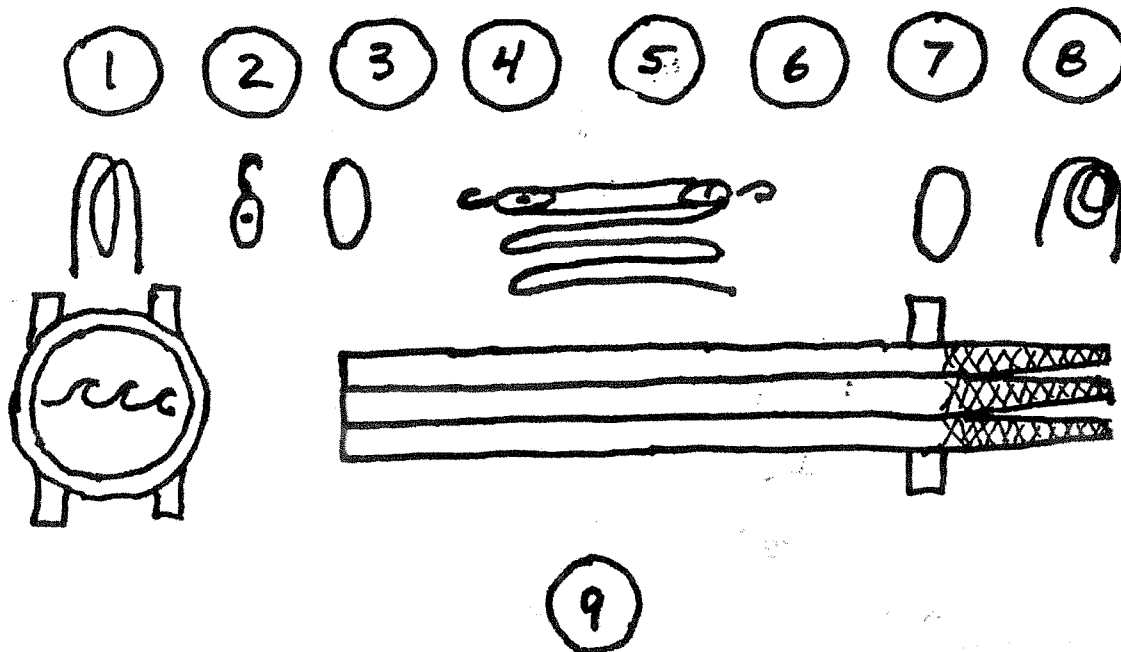

Near Pole #4 – Set up Gear as directed before initial run

Start at attention

Hold near pole steady (watch tapers)

Spread pole approximately 5' from barrel

Set base of pole and help lift tripod

Center tackle over barrel on Cox'n's commands

Hoist and lower barrel

Break down tripod

Assist tackle with block and tackle

Return to attention

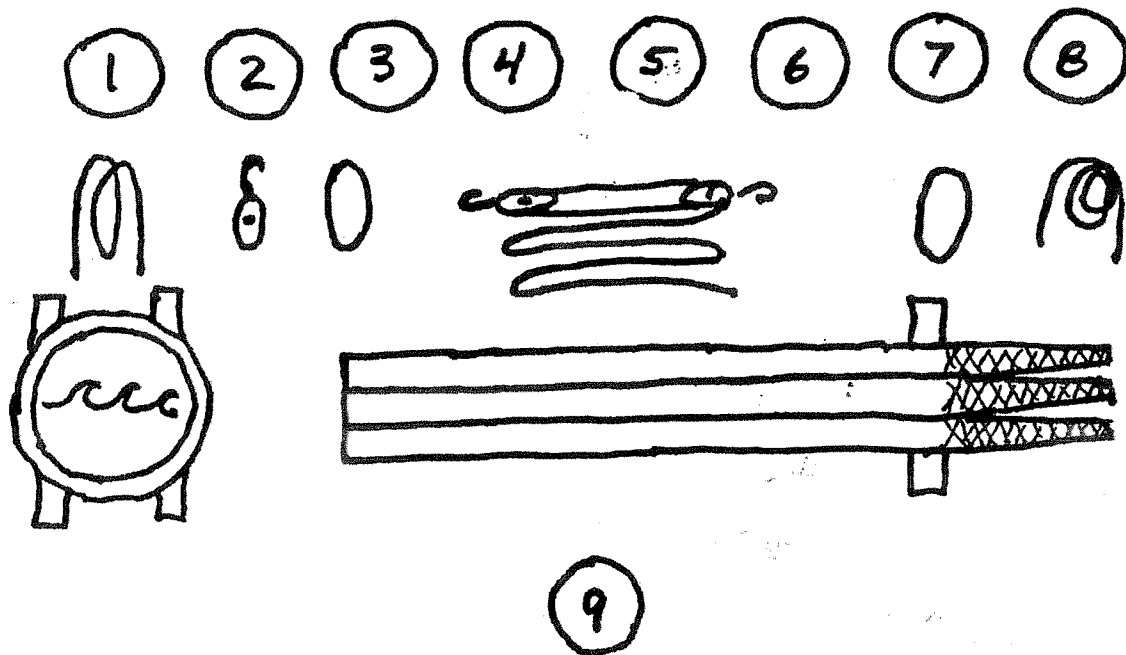

Far Pole #5 – Set up Gear as directed before initial run

Start at attention

Hold far pole steady (watch tapers)

Spread pole approximately 5' from barrel

Set base of pole and help lift tripod

Center tackle over barrel on Cox'n's commands

Hoist and lower barrel

Break down tripod

Assist center pole to straighten poles (top end)

Return to attention

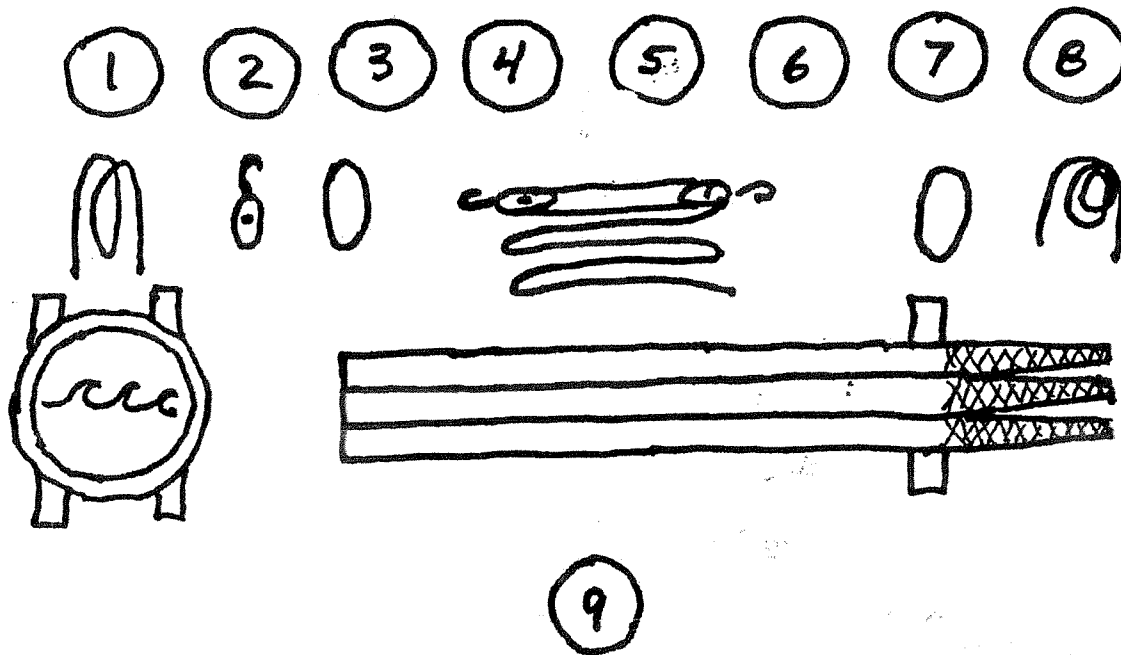

Tackle #6 – Work with popper/straighten and lay down tackle

Start at attention

Hook grommet to top block

Drag tackle to top of poles

When poles are spread, loop grommet over pole that points down (stop tripod if necessary)

Follow tackle as tripod rises – MAINTAIN hold on tackle

Hook lower block to barrel hitch. Hold center for cox'n.

Assist hoisting and lowering barrel – be closest to barrel

Unhook tackle and grasp lines just above lower block

Run and pull tripod over – DON'T LOOK BACK!

Pull grommet off poles with tackle

Give lower block to near pole

Shorten to approx. 5' – 6'

Lay tackle down near poles

Return to attention

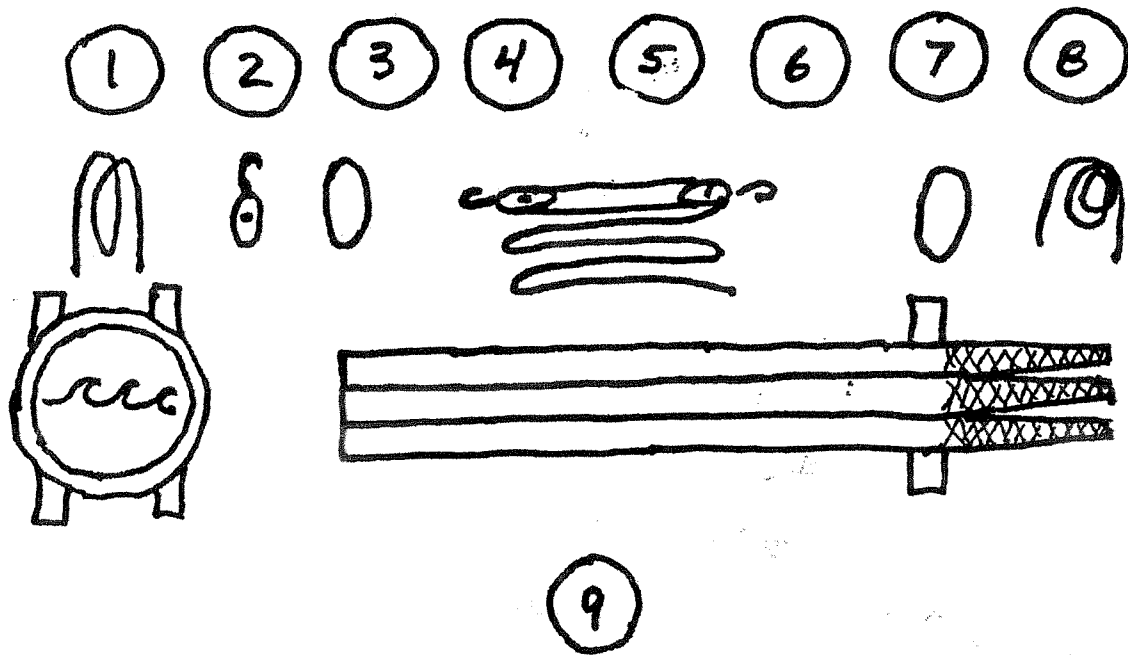

Popper #7 – Pre – run: Work with tackle, run out line, check and recoil

Start at attention

Straddle poles at base of tapers (facing tops of poles)

Lift and stack center pole; hold with ankles and hands

Watch tapers. HAND signal center pole if necessary

Lift Tripod and walk hands on side pole opposite head lasher

Stretch out hauling line for crew.

Lift and lower barrel – stay near end of line

Catch tripod just below head lashing – opposite head lasher

Run out and recoil hauling line

Place between poles and tackle

Return to attention

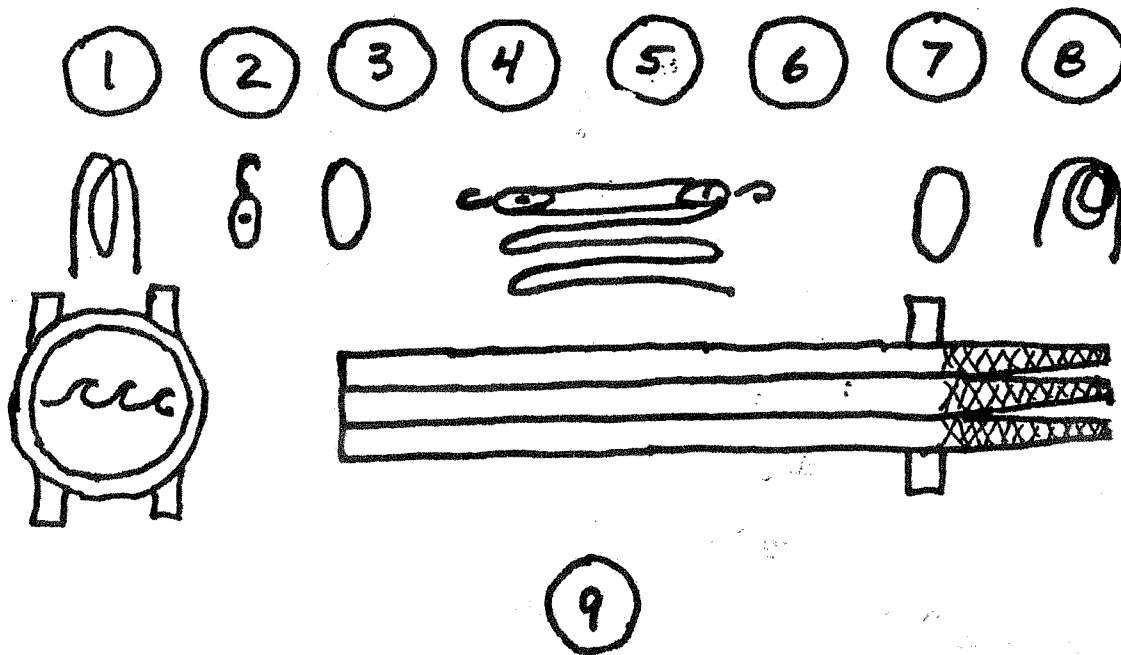

Head Lasher #8 – Pre – run: Coil Line and Place at Feet

Start at attention

Tie head lashing: 3 turns and square knot

Lift Tripod and walk hands on side pole opposite popper

Take hauling line between near pole and barrel back to center pole

Place bight of line into snatch block – be sure snatch block is closed and latched

Lift and lower barrel – stay near end of line

Catch tripod just below head lashing – opposite popper

Remove head lashing; recoil for next run

Return to attention

Cox'n - #9

Report to judge
Instruct crew to set up equipment
Start at attention

Commands

Mark, set, go!
Spread/lift
Spread/lift
Poles in or out
Poles left or right
Get on the line

Take a strain, EASY
Touch
Take it up
Bring it down
Touch
Down Easy
Get on your Poles
Get ready to break down

Break it down

Coil it up
Get poles straight
Crew Attention
Report to judge for next run or score card

Points to Watch

Square knot at head lashing
Center pole doesn't pull
Tackle doesn't swing free
Center tackle over barrel
Move center pole as little as possible
No strain!!!
Check the barrel hitch, tackle hook up & snatch block

Barrel hitch centered
Barrel hitch 1 & 2, hands off
Watch yard stick & judge
Watch yard stick & judge
Barrel hitch 1 & 2, hands on
Barrel not on any lines, set down easy
BE SURE ALL ARE READY!
Snatch block clear
Tackle clear
Popper and head lasher to catch poles
Center Pole to push

Tackle clears
Center pole doesn't stop
Head lasher and popper catch tripod

No lines outside of barrel chocks and tips of poles